

DJ SPOT 300



User Instructions

American DJ
6122 S. Eastern Ave.
Los Angeles CA. 90040
www.americandj.com

Rev. 3/08

DJ Spot 300 Table of Contents

General Instructions.....	2
Customer Support.....	3
Safety Precautions.....	4
Features.....	5
Registration.....	5
Controls and Functions.....	6
Set-Up.....	9
System Menu.....	12
Operating Modes.....	15
Fuse and Lamp Replacement.....	17
DMX Traits.....	19
Cleaning.....	21
Trouble Shooting.....	21
Warranty.....	22
Specifications.....	23

DJ Spot 300

General Instructions

To optimize the performance of this product, please read these operating instructions carefully to familiarize yourself with the basic operations of this unit. These instructions contain important safety information regarding the use and maintenance of this unit. Please keep this manual with the unit, for future reference.

Caution! There are no user serviceable parts inside this unit. Do not attempt any repairs yourself, doing so will void your manufactures warranty. In the unlikely event your unit may require service please contact American DJ®.

During operation the housing may become extremely hot. Avoid touching the unit with bare hands while in use.

American DJ® will not accept any liability for any resulting damages caused by the non-observance of this manual or any unauthorized modification to this unit.

Unpacking: Thank you for purchasing the DJ Spot 300 by American DJ®. Every DJ Spot 300 has been thoroughly tested and has been shipped in perfect operating condition. Carefully check the shipping carton for damage that may have occurred during shipping. If the carton appears to be damaged, carefully inspect your fixture for any damage and be sure all equipment necessary to operate the unit has arrived intact. In the event damage has been found or parts are missing, please contact our toll free customer support number for further instructions. Please do not return this unit to your dealer without contacting customer support first.

Introduction: The DJ Spot 300 is a eight channel, moving head, intelligent DMX fixture. The fixture can operate in three different operating modes; stand alone, sound-active, or in a Master/Slave configuration. The DJ Spot 300 comes with several built in programs and is best used in multiples of four. *For best results use fog or special effects smoke to enhance the beams projections.*

During the initial start-up or use of this product a light smoke or smell may arise from the unit. This is a normal process and is cause by the heat associated with the lamp.

Customer Support: American DJ® provides a toll free customer support line, to provide help and to answer any question should you encounter problems during your set up or initial operation. You may also visit us on the web at www.americandj.com for any comments or suggestions. Service Hours are Monday through Friday 9:00 a.m. to 5:00 p.m. Pacific Standard Time.

Voice: (800) 322-6337

Fax: (323) 582-2941

E-mail: support@americandj.com

To purchase parts online visit <http://parts.americandj.com>

Warning! To prevent or reduce the risk of electrical shock or fire, do not expose this unit to rain or moisture.

Warning! *This may cause severe eye damage. Avoid looking directly into the light source at all times!*

For Your Own Personal Safety, Please Read and Understand This Manual Completely Before You Attempt To Install Or Operate This Unit!

- To reduce the risk of electrical shock or fire, do not expose this unit rain or moisture
- Do not spill water or other liquids into or on to your unit.
- Be sure that the local power outlet match that of the required voltage for your unit.
- Do not attempt to operate this unit if the power cord has been frayed or broken.
- Do not attempt to remove or break off the ground prong from the electrical cord. This prong is used to reduce the risk of electrical shock and fire in case of an internal short.
- Disconnect from main power before making any type of connection.
- Do not remove the cover under any conditions. There are no user serviceable parts inside.
- Never operate this unit when it's cover is removed.
- Always be sure to mount this unit in an area that will allow proper ventilation. Allow about 6" (15cm) between this device and a wall.
- Do not attempt to operate this unit, if it becomes damaged.
- This unit is intended for indoor use only, use of this product outdoors voids all warranties.
- Always mount this unit in safe and stable matter.
- Power-supply cords should be routed so that they are not likely to be walked on or pinched by items placed upon or against them, paying particular attention to cords at plugs, convenience receptacles, and the point where they exit from the appliance.
- Cleaning -The fixture should be cleaned only as recommended by the manufacturer. See page 22 for cleaning details.
- Heat -This fixture should be situated away from heat sources such as radiators, heat registers, stoves, or other appliances (including amplifiers) that produce heat.
- The fixture should be serviced by qualified service personnel when:
 - A. Objects have fallen, or liquid has been spilled into the appliance.
 - B. The appliance has been exposed to rain or water.
 - C. The appliance does not appear to operate normally or exhibits a marked change in performance.

DJ Spot 300

Features

- Micro-Stepping Motors for Smooth Color and Gobo Transitions
- DMX-512 Protocol Compatible (Uses Eight DMX Channels)
- Independent Gobo and Color Wheels
- 7 Gobos + Spot - All Replaceable
- 9 Colors, Plus White - With Rainbow
- Strobing in All Colors and Gobo Shake
- 3 Operating Modes - Master/Slave; Stand Alone, Sound Active; Universal DMX-512
- Internal Microphone
- ZB-EHJ 24v/250w
- Manual Focus Lens
- 540° Pan Movement
- 265° Tilt Movement
- Digital Display for Address and Function Setting
- High Velocity Fans for continuous use (no duty cycle)

DJ Spot 300

Product Registration

The DJ Spot 300 carries a one year limited warranty. Please fill out the enclosed warranty card to validate your purchase. All returned service items whether under warranty or not, must be freight pre-paid and accompany a return authorization (R.A.) number. The R.A. number must be clearly written on the outside of the return package. A brief description of the problem as well as the R.A. number must also be written down on a piece of paper and included in the shipping carton. If the unit is under warranty, you must provide a copy of your proof of purchase invoice. You may obtain a R.A. number by contacting our customer support team on our toll free customer support number. All packages returned to the service department not displaying a R.A. number on the outside of the package will be returned to the shipper at the shippers cost.

DJ Spot 300

Controls and Functions

FRONT

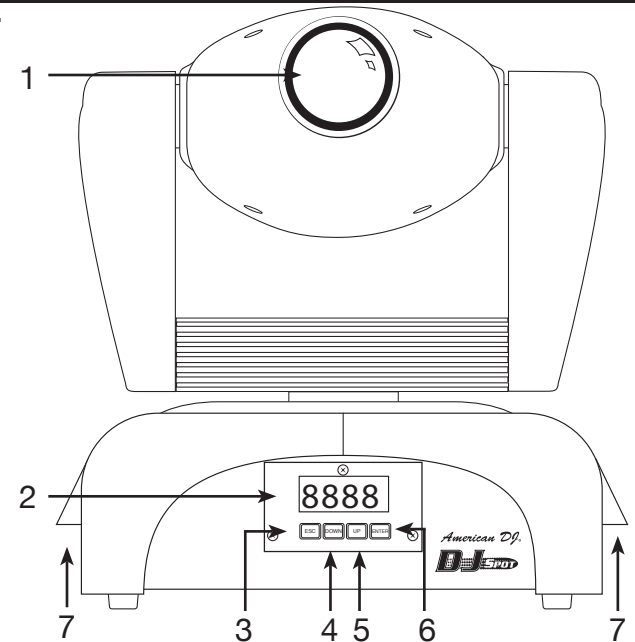

REAR

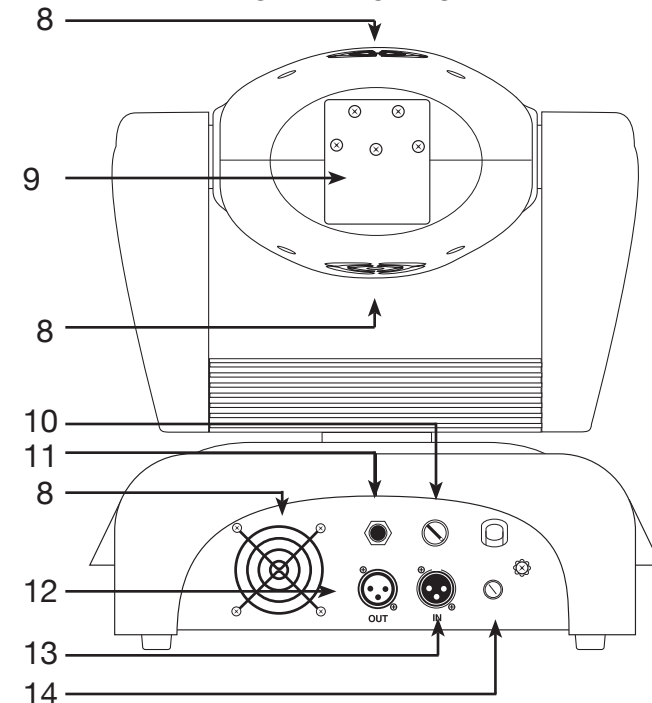

- 1. Lens Assembly** - This high quality lens is a fully focusing. Focus the lens by manually turning the lens in a clockwise or counter-clockwise direction until the desired effect is achieved.
- 2. Digital Display** - This display shows the menu and operating functions that you can choose from.
- 3. ESC (Escape) Button** - This button is used to exit menus.
- 4. Down Button** - This button is used to scroll backwards through certain menus only.
- 5. Up Button** - This button is used to scroll forward when navigating through the system menu.
- 6. Enter Button** - This button is used to select and confirm a function when working in the system menu. It is also used to exit certain menus.
- 7. Carrying Handles** - This includes built-in carrying handles. Be sure to always handle the unit by the built-in handles. Never lift or carrying the unit by head or yoke. Pulling on or transporting the unit by the moving head may severely damage the unit and will void the unit warranty.
- 8. Cooling Fan** - This unit is equipped with three high velocity variable fans to aid in the cooling process. These fans are designed to vary their velocity at different operating temperatures, to provide better cooling when the unit reached higher operating temperatures associated with long usage. Be sure to never obstruct the cooling fans during normal usage. Also, be sure to keep the vents clean at all times. A blocked or malfunctioning cooling system may shorten lamp life and unit reliability.
- 9. Lamp Assembly and Access Plate** - This plate accesses the lamp socket assembly. The unit includes a spring mounted LL-EHJ 24v/250w halogen lamp. Be sure to only replace with same type lamp. After replacing a lamp be sure the lamp is centered in the reflector. See page 18 for details on installing and optimizing replacement lamps. Never operate this unit with the lamp exposed, this lamp emits strong UV radiation.
- 10. Audio Sensitivity Knob** - This will adjust the audio sensitivity of the

- INTERNAL MICROPHONE. Turning the sensitivity knob in the clockwise direction will increase the sensitivity to sound. Turning the knob in the counter clockwise direction will decrease the fixture's sensitivity to sound.
- 11. Controller Jack** - This jack is for use with the optional controller only. Do not attempt to connect an audio signal this jack, this will damage the PC board and void your manufactures warranty!
 - 12. XLR Output Jack** - This jack is used to transmit the incoming DMX signal to another DMX fixture, or transmit a Master/Slave signal to the next DJ Spot 300 in the chain. For best results in DMX or Master/Slave mode terminate this jack if it is the last unit in the chain. See "Terminator" on page 10.
 - 13. XLR DMX Input Jack** - This jack is used to receive an incoming DMX signal or Master/Slave signal.
 - 14. Microphone** - This microphone receives external low frequencies to trigger the unit in Sound-Active mode. This microphone is designed to receive low frequency sounds only, tapping on the microphone and high pitch sounds may not trigger the unit.

Power Supply: Before plugging your unit in, be sure the source voltage in your area matches the required voltage for your American DJ® DJ Spot 300. The American DJ® DJ Spot 300 is available in a 120v only. Because line voltage may vary from venue to venue, you should be sure your unit voltage matches the wall outlet voltage before attempting to operate you fixture.

DMX-512: DMX is short for Digital Multiplex. This is a universal protocol used by most lighting and controller manufactures as a form of communication between intelligent fixtures and controllers. A DMX controller sends DMX data instructions from the controller to the fixture. DMX data is sent as serial data that travels from fixture to fixture via the DATA “IN” and DATA “OUT” XLR terminals located on all DMX fixtures (most controllers only have a DATA “OUT” terminal).

DMX Linking: DMX is a language allowing all makes and models of different manufactures to be linked together and operate from a single controller, as long as all fixtures and the controller are DMX compliant. *To ensure proper DMX data transmission, when using several DMX fixtures try to use the shortest cable path possible. The order in which fixtures are connected in a DMX line does not influence the DMX addressing. For example; a fixture assigned a DMX address of 1 may be placed anywhere in a DMX line, at the beginning, at the end, or anywhere in the middle. Therefore, the first fixture controlled by the controller could be the last fixture in the chain. When a fixture is assigned a DMX address of 1, the DMX controller knows to send DATA assigned to address 1 to that unit, no matter where it is located in the DMX chain.*

Data Cable (DMX Cable) Requirements (For DMX and Master/Slave Operation): The DJ Spot 300 can be controlled via DMX-512 protocol.

The DJ Spot 300 is a eight channel DMX unit. The DMX address is set electronically using the controls on the side panel of the unit. Your unit and your DMX controller require a standard 3-pin XLR connector for data input and data output (Figure 1). If you are making your own cables, be sure to use standard two conductor shielded cable (This cable may be purchased at almost all professional sound and lighting stores). Your cables should be made with a male



Figure 1

and female XLR connector on either end of the cable. Also remember that DMX cable must be daisy chained and cannot be split.

Notice: Be sure to follow figures two and three when making your own cables. Do not use the ground lug on the XLR connector. Do not connect the cable’s shield conductor to the ground lug or allow the shield conductor to come in contact with the XLR’s outer casing. Grounding the shield could cause a short circuit and erratic behavior.

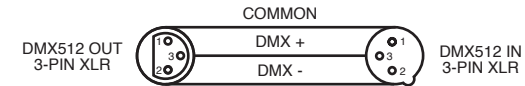

Figure 2

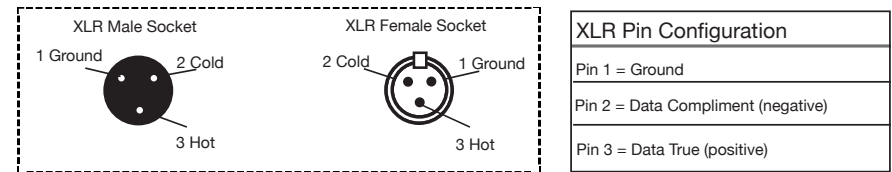

Figure 3

Special Note: Line Termination. When longer runs of cable are used, you may need to use a terminator on the last unit to avoid erratic behavior. A terminator is a 90-120 ohm 1/4 watt resistor which is connected between pins 2 and 3 of a male XLR connector (DATA + and DATA -). This unit is inserted in the female XLR connector of the last unit in your daisy chain to terminate the line. Using a cable terminator (ADJ part number Z-DMX/T) will decrease the possibilities of erratic behavior.



Termination reduces signal errors and avoids signal transmission problems and interference. It is always advisable to connect a DMX terminal. (Resistance 120 Ohm 1/4 W) between PIN 2 (DMX-) and PIN 3 (DMX+) of the last fixture.

Figure 4

5-Pin XLR DMX Connectors. Some manufactures use 5-pin XLR connectors for DATA transmission in place of 3-pin. 5-pin XLR fixtures may be implemented in a 3-pin XLR DMX line. When inserting standard 5-pin XLR connectors in to a 3-pin line a cable adaptor must be used, these adaptors are readily available at most electric stores. The chart below details a proper cable conversion.

3-Pin XLR to 5-Pin XLR Conversion		
Conductor	3-Pin XLR Female (Out)	5-Pin XLR Male (In)
Ground/Shield	Pin 1	Pin 1
Data Compliment (- signal)	Pin 2	Pin 2
Data True (+ signal)	Pin 3	Pin 3
Not Used		Pin 4 - Do Not Use
Not Used		Pin 5 - Do Not Use

On-Board System Menu. The DJ Spot 300 comes with an easy to navigate system menu. This next section will detail the functions of each command in the system menu. You can leave any menu setting without making any changes by pressing the ESC (ESCAPE) button.

MAIN MENU -

R.001 - DMX Address Setting

1. Press the ESCAPE button until “R.001” is displayed. Press the ENTER button to adjust the DMX address.
2. Tap the UP or DOWN button until the address that you want is displayed, press the ENTER button.

TEST - This function will activate the internal test modes.

1. Press the ESCAPE (ESC) button until “R.001” is displayed. Then press the UP button until “TEST” is displayed. Press the ENTER button to choose a test mode.

AUDI - This function is the Sound Active mode.

1. Press the ESCAPE (ESC) button until “R.001” is displayed. Then press the UP button until “AUDI” is displayed. Press the ENTER button.
2. Press the UP button to display “YES”. Press ENTER to confirm.
3. You can adjust the audio sensitivity of the unit by turning the audio sensitivity knob clockwise, located in the rear.

Note: When the unit is in Sound Active mode, “test run” will continuously flash on the LCD screen.

R.PAN - The movement of the Pan will be reversed.

1. Press the ESCAPE (ESC) button until “R.001” is displayed. Then press the UP button until “R.PAN” is displayed.

2. Press the UP button to choose “ON” or “OFF”, then press ENTER to confirm.
3. Press ESC to return to the main menu..

R.TILT - The movement of the Tilt will be reversed.

1. Press the ESCAPE (ESC) button until “R.001” is displayed. Then press the UP button until “R.TILT” is displayed.
2. Press the UP button to choose “ON” or “OFF”, then press ENTER to confirm.
3. Press ESC to return to the main menu.

DISP - This function will reverse the display 180°.

1. Press the ESCAPE (ESC) button until “R.001” is displayed. Then press the UP button until “DISP” is displayed. Press the ENTER button. “TURN” will now be displayed.
2. Tap the UP button to change the display and press ENTER to confirm the new display.
3. Press ESC to return to the main menu.

VERS - Use this function to display the Software version of the unit.

1. Press the ESCAPE (ESC) button until “R.001” is displayed. Then press the UP button until “VERS” is displayed. Press the ENTER button.
2. Tap the UP button until “SET” is displayed, press ENTER.
3. Tap the UP button until “VER” is displayed, press ENTER.
4. The display will show “V-X.X”, “X.X” stands for the version number, such as the display may show “V-1.0”, “V-2.6” etc.
5. Press ENTER or EXIT/DN to exit.

DEFR - With this function you can restore the factory settings of the device.

1. Press the ESCAPE (ESC) button until “R.001” is displayed. Then press the UP button until “DEFR” is displayed. Press the ENTER button.
2. The display will show “YES”.
3. Press ENTER to confirm.
7. Press EXIT/DN to return to the main menu.

When you exit this function, the unit will begin to reload data.

Operating Modes: The DJ Spot 300 can operate in three different modes. This next section will detail the differences in the operating modes.

- **Stand alone mode -**

The unit will react to sound, chasing through the built-in programs.

- **Master/Slave mode -**

You can daisy chain up to 16 units together to get a synchronized light show without the need of an external controller. The units will react to sound chasing through the several built-in programs.

- **DMX control mode -**

This function will allow you to control each individual fixtures traits with a standard DMX-512 controller such as the LSC® Show Designer.™

Universal DMX Control: This function allows you to use a universal DMX-512 controller such as the Elation DMX Operator™ or Elation Show Designer™ to control the various DMX traits. A DMX controller allows you to create unique programs tailored to your individual needs.

1. The DJ Spot 300 uses eight DMX channels. Channel 1 controls pan, channel 2 controls tilt, channel 3 controls the gobo wheel, channel 4 controls gobo rotation, channel 5 controls the color wheel, channel 6 controls the strobe effect, channel 7 controls gobo shake, and channel 8 controls the speed of the pan and tilt. See pages 20-21 for a detailed description of the DMX traits.
2. To control your fixture in DMX mode, follow the set-up procedures on pages 9-11 as well as the set-up specifications that are included with your DMX controller.
3. Use the controller's faders to control the various DMX fixture traits.
4. This will allow you to create your own programs.
5. Follow the instruction on page 16 to set the DMX address.
6. For longer cable runs (more than a 100 feet) use a terminator on the last fixture.
7. For help operating in DMX mode consult the manual included with your DMX controller.

Stand-Alone Operation (Sound Active): This mode allows a single unit to run to the beat of the music, or run a internal program.

1. Press the ESCAPE (ESC) button until "TEST" is displayed. Then press the UP button until "AUDI" is displayed. Press the ENTER button.
2. Press the UP button to display "ON". Press ENTER to confirm. Then press the ESC button to exit.
3. You can adjust the audio sensitivity of the unit by turning the audio sensitivity knob clockwise, located in the rear. You may invert the pan and tilt functions by in the system menu by following the directions on page 13.

Master-Slave Operation (Sound Active): This function will allow you to link up to 16 units together and operate without a controller. The units will be sound activated. In Master-Slave operation one unit will act as the controlling unit and the others will react to the controlling units programs. Any unit can act as a Master or as a Slave.

1. Using standard XLR microphone cables, daisy chain your units together via the XLR connector on the rear of the units. Remember the Male XLR connector is the input and the Female XLR connector is the output. The first unit in the chain (master) will use the female XLR connector only - The last unit in the chain will use the male XLR connector only. For longer cable runs we suggest a terminator at the last fixture.
You do not have to assign the units Master/Slave. They will automatically fall into Master/Slave mode.
2. Use the sensitivity knob on the rear of the master unit to make it more or less sensitive to sound.

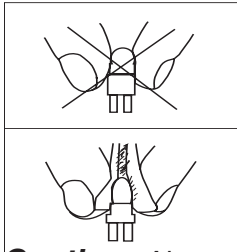

This fixture is fitted with a halogen lamp which is highly susceptible to damage if improperly handled. Never touch the lamp with your bare fingers as the oil from your hands will shorten lamp life. Also, never move the fixture until the lamps have had ample time to cool. Remember, lamps are not covered under warranty conditions.

Caution: Always replace with the exact same type lamp and fuse, unless otherwise specified by an authorized American DJ® service technician. Replacing with anything other than the specified part can damage your unit and will void your manufactures warranty.

Warning: If you continue to blow lamps or fuses, STOP using the unit. Contact customer support for further instructions, you may have to return the unit for servicing. Continuing to use the unit may cause serious damage.

Lamp Replacement: Caution! Never attempt to change the lamp while the fixture is plugged in. Always disconnect the main power and allow the unit ample time to cool before attempting to replace the lamp. Lamp replacement has been made simple by incorporating the use of a slide out socket assembly that is retained by thumb screws.

1. Be sure to follow the proper handling procedures that deal with discharge lamps.
2. Remove the two small screws (A,B) on the rear of the unit
3. After removing the screws, gently slide out the socket assembly from the rear of the unit to expose the lamp.
4. Carefully remove the old lamp and discard it in the trash.
5. Replace the lamp with an exact match and reassemble in reverse order.
6. After replacing the lamp follow the optimization procedures on the next page to be sure the lamp is center in the reflector

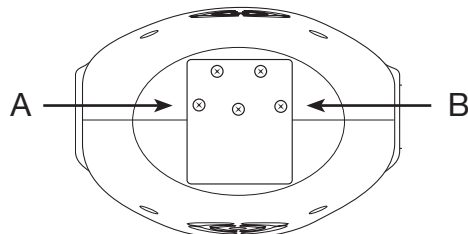

GOBO REPLACEMENT:

1. To change the gobos, you must remove the bottom half of the moving head. The bottom half of the moving head is where the fan is located.
2. Unscrew the four phillips screws, that secure the bottom half, and remove.
3. When you remove the bottom half, the gobo and color wheel will now be accessible. Turn the wheel with your hand until you find the gobo you would like to change. Turn the color wheel until the empty space is behind the gobo you would like to change.
4. Remove the gobo fixation-ring with a small flat-head screwdriver. Put your finger through the empty space in the color wheel, and push the gobo out towards the front. When doing this you do not need a lot of pressure. You can also use tweezers to gently pull the gobo out, or a small flat-head screwdriver and gently pry out the gobo.
5. Change the gobo, replace the fixation-ring, and reassemble the unit.

Fuse Replacement: Locate and remove the unit's power cord. Once the cord has been removed locate the fuse holder located inside the power socket. Insert a flat-head screw driver into the power socket and gently pry out the fuse holder. Remove the bad fuse and replace with a new one. The fuse holder has a built-in socket for a spare fuse be sure not to confuse the spare fuse with active fuse.

DJ Spot 300		DMX Traits
Channel	Value	Function
1	0 - 255	PAN
2	0 - 255	TILT
3 ↓		<u>COLOR WHEEL</u>
	0 - 7	WHITE
	8 - 14	RED
	15 - 21	RED/YELLOW
	22 - 28	YELLOW
	29 - 35	YELLOW/BLUE
	36 - 42	BLUE
	43 - 49	BLUE/GREEN
	50 - 56	GREEN
	57 - 63	GREEN/PURPLE
	64 - 71	PURPLE
	72 - 77	PURPLE/ORANGE
	78 - 85	ORANGE
	86 - 92	ORANGE/PINK
	93 - 99	PINK
	100 - 106	PINK/LIGHT BLUE
107 - 113	LIGHT BLUE	
114 - 120	LIGHT BLUE/LIGHT GREEN	
121 - 127	LIGHT GREEN	
128 - 255	RAINBOW EFFECT SLOW → FAST	
4 ↓		<u>GOBO WHEEL</u>
	0 - 15	SPOT
	16 - 31	GOBO 1
	32 - 47	GOBO 2
	48 - 63	GOBO 3
	64 - 79	GOBO 4
	80 - 95	GOBO 5
	96 - 111	GOBO 6
112 - 127	GOBO 7	

DJ Spot 300		DMX Traits cont.
Channel	Value	Function
4 ↓		<u>GOBO WHEEL CONT.</u>
	128 - 255	GOBO SCROLL SLOW → FAST
5 ↓		<u>GOBO ROTATION</u>
	0 - 85	FAST → SLOW
	86 - 170	SLOW → FAST
	171 - 178	NO ROTATION
	179 - 255	RANDOM ROTATION
6 ↓		<u>SHUTTER/STROBE</u>
	0 - 8	SHUTTER CLOSED
	9 - 253	STROBE
	254 - 255	SLOW → FAST SHUTTER OPEN
7	0 - 191	<u>SPECIAL FEATURES</u>
	191 - 255	GOBO SHAKE RESET
8	0 - 255	<u>PAN/TILT SPEED</u> FAST → SLOW

Fixture Cleaning: Due to fog residue, smoke, and dust cleaning the internal and external optical lenses and mirror should be carried out periodically to optimize light output. Cleaning frequency depends on the environment in which the fixture operates (i.e. smoke, fog residue, dust, dew). In heavy club use we recommend cleaning on a monthly basis. Periodic cleaning will ensure longevity, and crisp output.

1. Use normal glass cleaner and a soft cloth to wipe down the outside casing.
2. Use a brush to wipe down the cooling vents and fan grill.
3. Clean the external optics and mirror with glass cleaner and a soft cloth every 20 days.
4. Clean the internal optics with glass cleaner and a soft cloth every 30-60 days.
5. Always be sure to dry all parts completely before plugging the unit back in.

Trouble Shooting: Listed below are a few common problems that you may encounter, with solutions.

No light output from the unit;

1. Be sure you have connected your unit into a standard 120v wall outlet.
2. Be sure the external fuse has not blown. The fuse is located on the bottom panel of the unit.
3. Remove the lamp holder and be sure the lamp is seated in its socket properly. Occasionally lamps become loose during shipping be sure the lamp is push in to its socket all the way.
4. Be sure the fuse holder is completely and properly seated.

Unit does not respond to sound;

1. Low frequencies (bass) should cause the unit to react to sound. Tapping on the microphone, quiet or high pitched sounds may not activate the unit. Adjust the sound sensitivity knob.

1-YEAR LIMITED WARRANTY

A. American DJ® hereby warrants, to the original purchaser, American DJ® products to be free of manufacturing defects in material and workmanship for a period of 1 Year (365 days) from the date of purchase. This warranty shall be valid only if the product is purchased within the United States of America, including possessions and territories. It is the owner's responsibility to establish the date and place of purchase by acceptable evidence, at the time service is sought.

B. For warranty service, send the product only to the American DJ® factory. All shipping charges must be pre-paid. If the requested repairs or service (including parts replacement) are within the terms of this warranty, American DJ® will pay return shipping charges only to a designated point within the United States. If the entire instrument is sent, it must be shipped in its original package. No accessories should be shipped with the product. If any accessories are shipped with the product, American DJ® shall have no liability whatsoever for loss of or damage to any such accessories, nor for the safe return thereof.

C. This warranty is void if the serial number has been altered or removed; if the product is modified in any manner which American DJ® concludes, after inspection, affects the reliability of the product; if the product has been repaired or serviced by anyone other than the American DJ® factory unless prior written authorization was issued to purchaser by American DJ®; if the product is damaged because not properly maintained as set forth in the instruction manual.

D. This is not a service contract, and this warranty does not include maintenance, cleaning or periodic check-up. During the period specified above, American DJ® will replace defective parts at its expense, and will absorb all expenses for warranty service and repair labor by reason of defects in material or workmanship. The sole responsibility of American DJ® under this warranty shall be limited to the repair of the product, or replacement thereof, including parts, at the sole discretion of American DJ®. All products covered by this warranty were manufactured after January 1, 1990, and bear identifying marks to that effect.

E. American DJ® reserves the right to make changes in design and/or improvements upon its products without any obligation to include these changes in any products theretofore manufactured.

F. No warranty, whether expressed or implied, is given or made with respect to any accessory supplied with products described above. Except to the extent prohibited by applicable law, all implied warranties made by American DJ® in connection with this product, including warranties of merchantability or fitness, are limited in duration to the warranty period set forth above. And no warranties, whether expressed or implied, including warranties of merchantability or fitness, shall apply to this product after said period has expired. The consumer's and or Dealer's sole remedy shall be such repair or replacement as is expressly provided above; and under no circumstances shall American DJ® be liable for any loss or damage, direct or consequential, arising out of the use of, or inability to use, this product.

G. This warranty is the only written warranty applicable to American DJ® Products and supersedes all prior warranties and written descriptions of warranty terms and conditions heretofore published.

H. Lamps are not covered under this or any other warranty, either written or implied.

Model:	DJ Spot 300
Voltage*:	120v/60Hz or 230v/50Hz
Lamp:	ZB-EHJ, 24v/250w
Dimensions:	18"(L) x 14.5"(W) x 12"(H) 457mm x 368mm x 305mm
Colors:	9 Plus White
Gobos:	7 + Spot
Weight:	19 Lbs. / 8.8 kgs.
Fuse:	5A (120v) / 2A (220v)
Duty Cycle:	None
DMX:	8 Channels
Sound Active:	Yes
Working Position:	Any Safe, Secure Position
Warranty:	1 Year (365 days)

*Voltage is preset at the factory and is not user selectable

Please Note: Specifications and improvements in the design of this unit and this manual are subject to change without any prior written notice.

©American DJ Supply
 American DJ World Headquarters:
 6122 S. Eastern Ave. Los Angeles, CA 90040 USA
 Tel: 323-582-2650 / Fax: 323-582-2610
 Web: www.americandj.com / E-mail: info@americandj.com

American DJ Europe
 Junostraat 2
 6468 EW Kerkrade
 Netherlands
service@americandjeurope.com / www.americandjeurope.com
 Tel: +31 45 546 85 00 / Fax: +31 45 546 85 99